

NORSEMAN 110-G

SPINCAST REEL

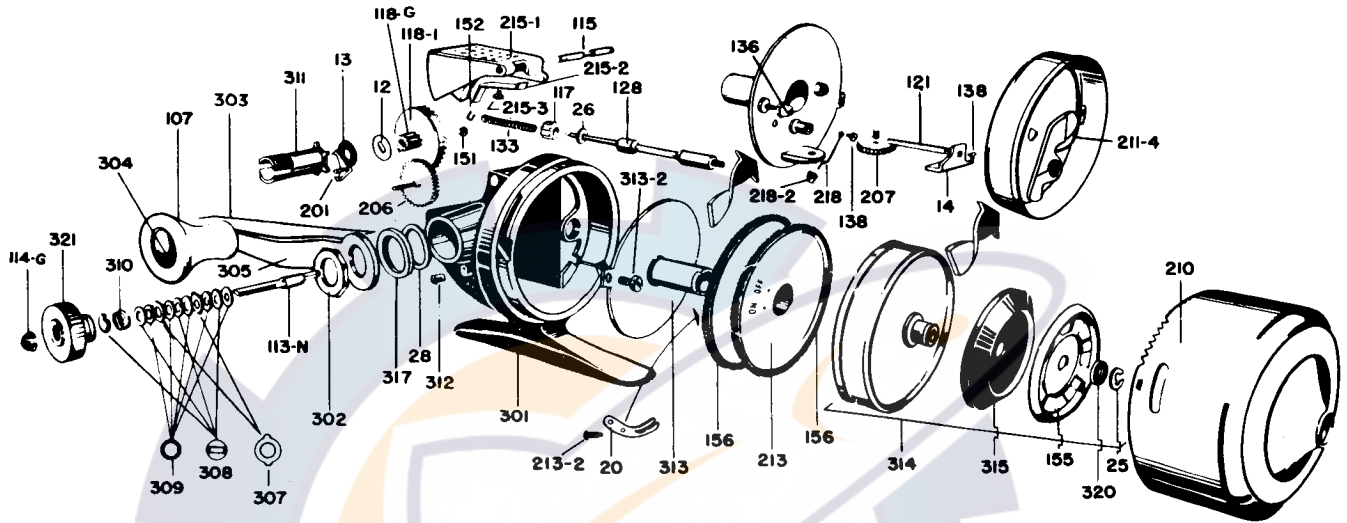

PARTS AND PRICE LIST FOR NORSEMAN 110-G

PART NO.	PART NAME	LIST PRICE	PART NO.	PART NAME	LIST PRICE	PART NO.	PART NAME	LIST PRICE
110-12	Click Washer	\$.15	110-128	Main Gear Shaft	2.00	110-218-2	Cover Locking Spring Button	.15
110-13	Friction Washer	.10	110-133	Main Shaft Spring	.15	110-301	Housing Assembly	6.00
110-14	Smooth Wind Follower	.40	110-136	Bearing Plate Nut	.25	110-302	Crank Nut	.40
110-20	Spool Lock	.30	110-138	Shaft/Spring Screw	.10	110-303	Crank Handle Assembly	2.25
110-25	Retaining Clip	.10	110-151	Main Gear Nut	.10	110-304	Crank Handle Rivet	.60
110-26	Main Shaft Washer	.10	110-152	Shaft Spring Retainer	.10	110-305	Crank Handle Arm	.70
110-28	Waffle Washer	.10	110-155	Feathering Ring	.25	110-307	Fixed Drag Washer	.15
110-107	Crank Handle	.40	110-156	Line Retainer	.20	110-308	Drag Washer	.10
110-113N	Crank Shaft	1.00	110-201	Anti Reverse Pawl	.60	110-309	Drag Friction Washer	.10
110-114G	Crank Shaft Nut	.25	110-206	Inner Gear	1.25	110-310	Drag Spring	.35
110-115	Control Button Pin	.35	110-207	Smooth Wind Gear	1.25	110-311	Crank Sleeve	2.25
110-117	Pinion Gear—Main Shaft	.60	110-210	Outer Cone	2.50	110-312	Oil Hole Cover	.25
110-118-1	Main Gear	1.25	110-211-4	Pickup Spring	.15	110-313	Bearing Plate Assembly	5.00
110-118G	Pinion Main Gear	.85	110-213-2	Drive Screw	.10	110-313-2	Bearing Plate Screw	.10
110-118B	Pinion Main Gear	.75	110-213	Line Spool	3.00	110-314	Pickup Housing Assembly	5.50
110-118-2	Main Gear Washer	.10	110-215-1	Control Button Assembly	.75	110-315	Line Brake	.35
110-121	Smooth Wind Shaft	.10	110-215-2	Control Button Spring	.30	110-317	Crank Handle Spacer	.35
110-122G	Crank Bushing	.40	110-5-3	Control Button Screw	.10	110-319	Bearing Plate Bushing	.25
110-123	Eyelet	.25	110-218	Cone Locking Spring	.40	110-320	Neoprene Washer	.10
						110-321	Drag Adjusting Nut	1.50

DISASSEMBLY, GREASING & OILING

1. Depress Outer Cone Locking Spring (218) and remove Outer Cone (210) with a counter-clockwise quarter turn. 2. Hold Crank Handle from turning and unscrew pickup Housing (314). **Note:** Rubber Line Brake (315) is cemented to Pickup Housing. 3. Turn Spool (213) to "off" position, disengaging Spool Lock (20), and slide from bushing. 4. Press out Control Button Pin (115) and lift out Control Button (215-1). 5. Unscrew Bearing Plate Nut (136) and Bearing Plate Mounting Screw (313-2) and lift out Bearing Plate (313) from Housing (301). Main Shaft (128) now slides free from bearing. 6. SmoothWind Assembly is dismantled by removing Shaft Screw (138). To avoid loss of parts or incorrect reassembly, disassembly beyond this point is not recommended. For a periodic

servicing of the reel, return it to your dealer for complete breakdown, cleansing and lubrication. **GREASING AND OILING.** Your NORSEMAN was properly lubricated when assembled. It should be cleaned and oiled after each fishing trip or more often if used excessively. For field maintenance, slip out Control Button and apply a light oil to all gears and shafts. Replace Control Button and remove Outer Cone and Pickup Housing. Put a drop of oil on Pickup Arm rivet. Spool Bearing and the Main Shaft. Remove Crank Nut and put a few drops on the end of the Crank Shaft. Occasionally apply a light grease to the Pinion Gear (117) and SmoothWind Follower (14).

NOTE: On some models of the 110-G, Part No. 110-118G Main Gear Pinion is replaced by 110-118B Main Gear Pinion and 110-118-2 Main Gear Washer (not shown). Washer is inserted between 110-118B Pinion and 110-118-1 Main Gear.

NOTE: When ordering parts, give reel part name, reel number and model.